



---

# **Mark III High Performance Extruders**





## Why every extruder we've ever built is still at work.

---

### Welex around the world.

Welex is the United States' leading exporter of extruders because we're set up to meet the needs of other countries.

Our experts speak and write many languages. We provide machines with English or metric calibrations. We meet the CE, ANSI, and NFPA standards—plus other certifications on request.

Welex extruders work long and hard.

Obviously, that means they're built to be exceptionally reliable, year after year.

But not so obviously, it means they're designed to meet your changing needs, year after year.

That's just the way we do business. We don't believe in planned obsolescence. We don't believe in change for its own sake. We don't believe in designing highly customized one-off extruders to handle only one kind of polymer under limited conditions. If we did, you'd pay dearly for design and construction costs. For purchasing a different machine for almost every different polymer. And for coping with outdated equipment when technology changes.

At Welex, we constantly study the needs of extruder users everywhere. And we meet those needs—at a good price, on good delivery schedules, and with good after-the-sale support.

So Welex extruders give you the most output for your investment by letting you switch from one polymer to another, depending on demand. By letting you run new polymers, as they're developed. By eliminating the need for pre-dryers with most polymers. By keeping start-up time to a minimum. In short, by adapting to your entire operation—not just a small part of it.

To keep you up and running, we maintain an extensive stock of spare parts. So you can get any part you need for any Welex ever made, usually with same day shipping.

In this catalog you'll find the latest results of our efforts to offer the most reliable, most flexible, and most productive extruders anywhere in the world. For use anywhere in the world.

## Take a close look.

---

**A component-by-component tour of a Welex extruder will give you an even better idea of our better ideas.**

### The drive train

The more power we put in, the more product you're going to put out. So we pack all the useful horsepower we can get into each extruder we build. Then we make sure the power's usable. With heavy-duty, heat-treated helical gears in an efficient, quiet, double-reduction drive. With a choice of ratios to give you screw speeds and torque to match the material you're running. With built-in long-life thrust bearings. And we directly couple the motor to the gear reducer for maximum efficiency.

### The screw and cylinder

We provide the most advanced screw designs available, with Stellite or Colmonoy surfaced flights, so they'll last a long time. Plus our full-diameter screw shanks provide the highest possible torque capability, to keep up with your demands for higher output. Cylinders are bimetallic lined and designed for 10,000 psi working pressures. With special linings for highly abrasive or corrosive materials.

## Venting

A fully proven high performance venting system is provided where appropriate. Welex patented double venting permits running the extruder full out, without a dryer, even with materials which contain high levels of volatiles, such as ABS, acrylics and polycarbonate.

PET can advantageously be run on single vented extruders with special high vacuum pumps (Welex V-PET system).

You can often save the cost of a dryer. Save the cost of the energy to run it. And save space.

When you run less volatile polymers like polyethylene, simply plug the vents. Or we can supply a non-vented extruder.

## Heating and cooling

Air cooling used to be all you needed. But not any more, for high performance. You have too many materials to run, over too broad a range of conditions. So we use positive closed-loop liquid cooling, paired with cast-in aluminum heaters, for the closest possible control.

## Screen changer

Screen changers provide practically uninterrupted continuous production. Hydraulically operated slide plate types are most popular. For highly contaminated material we can also supply various continuous types. A screen changer will easily pay for itself in a short time by eliminating downtime for screen cleaning and by protecting product quality.

## Gear pump

Nothing enhances the performance of an extruder like a Welex-built gear pump. It ensures volumetric output stability, using a precision digital drive and automatic pressure control. Completely integrated into the extruder when purchased together (as shown below).

## Static mixer

Our static mixers eliminate viscosity variations simply and reliably.

Details on these areas, and a dozen other good ideas, are in the next few pages. As you look through them, you'll find that we're continuing to design and build with your needs foremost, offering extruders that combine ease of operation, low maintenance and the greatest possible production capacity for the money.

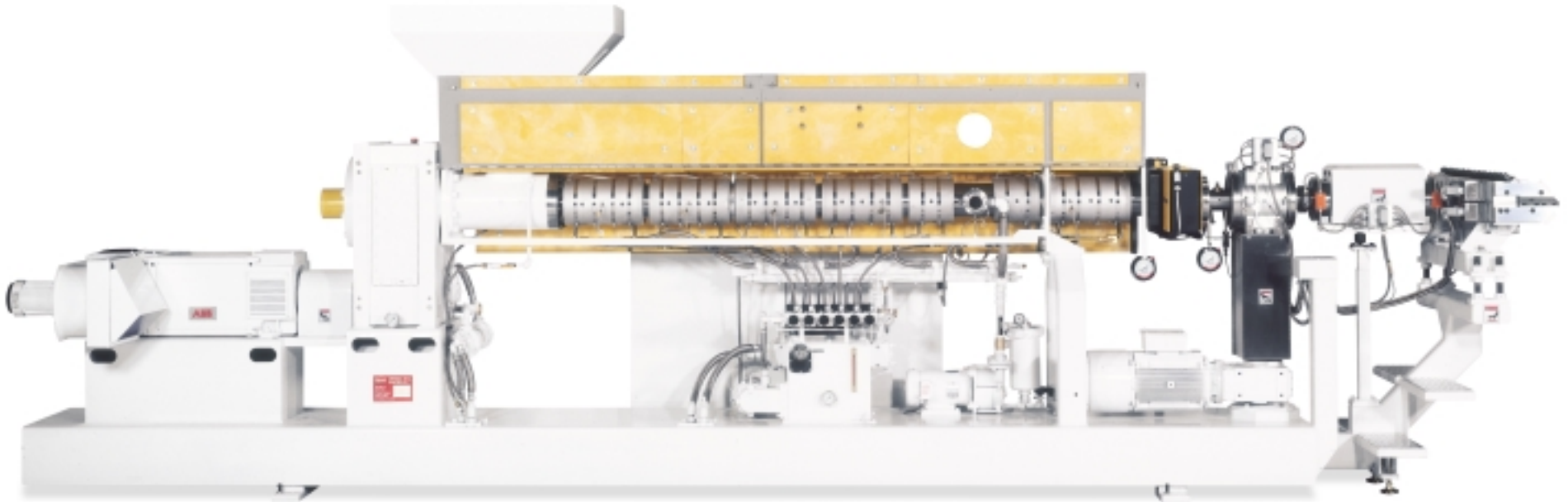

# Sixteen of your best ideas make Welex extruders the best buy—for now and for the future.

You said you wanted extruders that could switch from polystyrene to PET.

You said you wanted extruders that would keep up with new screw designs, higher speeds, more horsepower, higher output rates.

You said you wanted extruders with long, useful service lives, with considerably less downtime than you had been bothered with.

Here's how we did it.

## 1. The drive motor

Your choice of AC or DC infinitely variable speed drives directly coupled to reducer for maximum efficiency. In-line arrangement for easy motor access (1-A). Or tuck-under design to minimize floor space (1-B).

## 2. High efficiency gears

Heavy-duty, heat-treated helical gears equipped with shaft-driven oil pumps and oil cooler. Wide

selection of reduction ratios offered to suit all materials.

## 3. Thrust bearing

Life expectancy in most cases is well in excess of 30 years continuous operation. Thrust bearings are selected for practical life expectancies exceeding that of most of their users.

## 4. Feed opening

Large rectangular standard. Round with lining, optional, for use with crammer feeders.

## 5. Heating elements

Cast-in heater/cooler elements last a long time, heat quickly and uniformly.

## 6. Cooling

Cast-in stainless steel tubes run parallel with heating elements for efficient, uniform cooling. Closed-loop, non-ferrous distilled water cooling is automatically

adjusted by solenoid valves and needle-flow control valves. Heating and cooling in each zone precisely maintained by microprocessor-based temperature controllers.

## 7. High performance screw

Designed for your requirements. Colmonoy tipped for long life at all temperatures. Cored for cooling. Bimetallic lined cylinder.

## 8. Piping and wiring

Fully piped and prewired at the factory. Ready for single power drop installation.

## 9. Guards fully insulated

One-piece, hinged. No loose parts, no disassembly needed for access.

## 10. Base

Heavy fabricated steel, with everything in place. You don't have to put our extruder together yourself.

## 11. Venting (when applicable)

Eliminates predrying for most polymers. Our patented two-stage venting is available for difficult to dry materials. Vents can be plugged in minutes. Also available non-vented.

## 12. Screen changer (optional)

For continuous operation without shut down. Hinged swing-bolt gate standard.

## 13. Gear pump (optional)

Ensures absolute volumetric output stability.

## 14. Static mixer (optional)

Provides thermal and viscosity homogeneity.

## 15. Die (optional)

Designed to produce single or multilayer sheet without modification. Strand dies also offered.

## 16. The person

One. One contact from beginning to end. To help you select the right machine. To provide all the after-sale service you need. Single-source responsibility. No divided, confused authority.

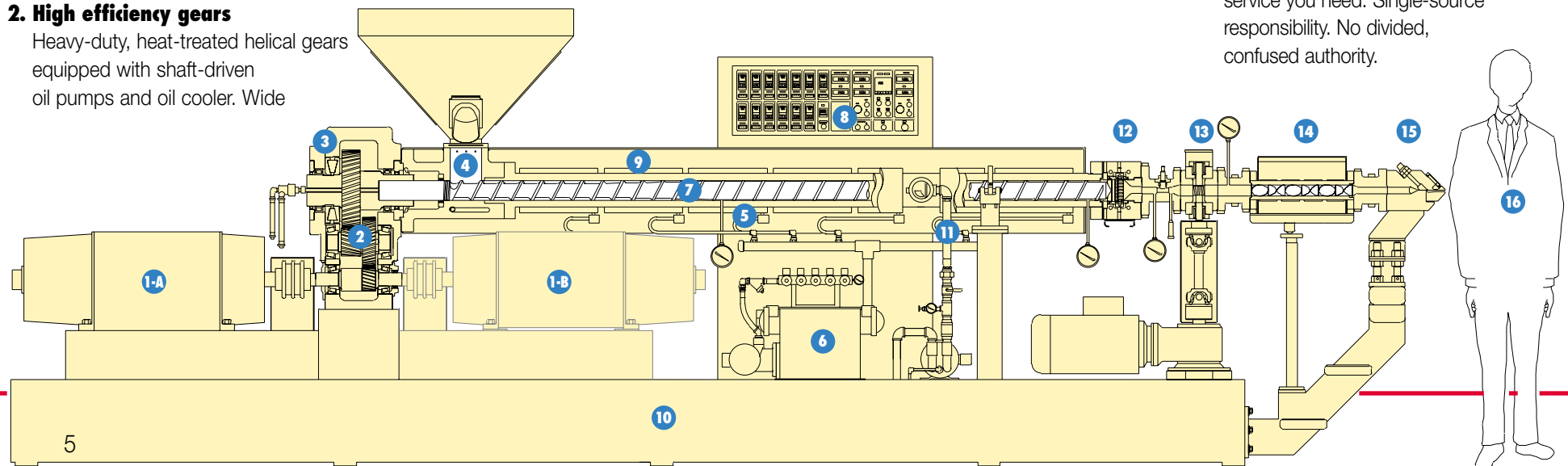

## Welex extruders: Everywhere you look, you find production-oriented design details.

Even a quick glance at a Welex extruder shows you that it's designed to be part of your process, not part of your problems.

Everything is easily accessible. For maintenance and service, the drive motor, closed-circuit liquid cooling system, and control panel are all mounted right on the rugged machine base (remote panels are optional). The fully insulated guard is hinged for easy access to heaters, wiring and piping. There are no loose sheet metal components to be misplaced, damaged, tripped over, or lost.

**Welex gear reducers** use heavy-duty heat-treated gears. We offer a choice of ratios to give you screw speeds and torque to match the material you're running. And our positive direct-coupled drive eliminates belt maintenance and maximizes energy efficiency.

**The large-capacity hopper** includes a sight glass, heavy-duty manual shut-off valve, and side discharge. Options shown here include our pneumatic hopper shut-off for remote control, and a drawer magnet to remove magnetic material from feed before it gets into the extruder.

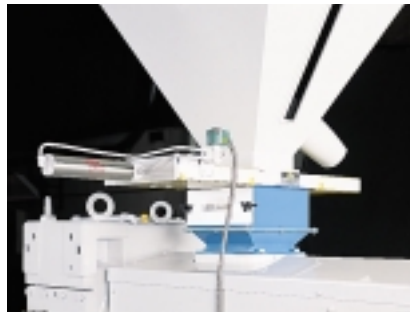

Remote control hopper shut-off  
with drawer magnet



Crammer feeder

**Our rectangular feed section** is generously proportioned for unrestricted material feed, and is interchangeable with round-opening hard-lined type for use with crammer or melt feeders. The entire section is water-jacketed for cooling and is prepped to the cooling system.

The feed section is an integral structural member of the extruder, acting as a support between the gear reducer and cylinder for precise alignment. A large air space behind the feed section permits easy access to the critical screw seal area and prevents material leakage into gear reducer seals. For powder, vacuum or pressure feed, special screw shaft seals are available.

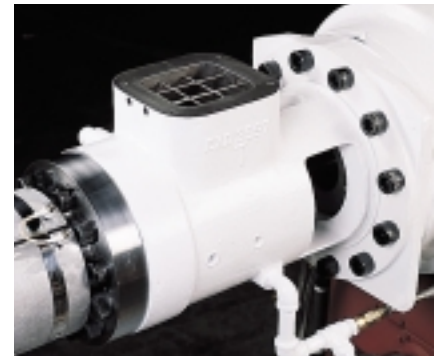

**Welex extrusion screws** are optimized for your application and built of materials to provide long trouble free service.

Our designers use the most advanced computer technology available combined with our practical experience in supplying many thousands of extruders. We pioneered vented and double vented extrusion and are its leading practitioners, eliminating the need for drying most materials.

Welex is consistently the world's first choice for new polymer extrusion, giving us the leading edge (and by far the largest share) in such markets as PP and PET.

Most of our screws have hard surfaced flights with TIG applied Colmonoy or Stellite to ensure long wear running common polymers. Other special materials of construction are available for abrasive or corrosive processes.



**Positive heating and cooling** are provided to the cylinder by parallel cast-in-aluminum heating and cooling coils to assure uniform temperature control.

The aluminum castings are precision machined to fit the cylinder for maximum heat transfer.

Cooling is done by a non-ferrous closed-circuit system, filled with distilled water to avoid fouling of cooling lines. Water is circulated by a large-capacity pump to a distribution manifold, with a digital temperature controller operating solenoid valves to provide cooling whenever required. Needle valves permit precise regulation of the cooling rate in each zone. Feed section cooling is separate, manually controlled and tied into the prepiped cooling system.

After passing through the cooling coils on the cylinder, the water and steam are condensed in a heat exchanger and returned to the reservoir. The reservoir has a sight glass and thermometer.

**Venting** can be a nuisance unless it's done right. Welex has done it right: the vents are efficient and streamlined. The horizontal vent—horizontal to prevent condensate from dripping back into the extruder—is directly piped to a vacuum pump. In certain cases, separators or filters are supplied. The short, easily removable piping permits fast cleaning in case of an upset. A hinged sight glass permits constant observation of vent performance.

When you don't want to vent, change-over is easy. The full-access guard swings out of the way, and you have to remove only two bolts to replace the stainless steel vent stack with a conforming plug and clamp. The two piece vent plug clamp is actually stronger than the cylinder itself.

Our patented two-stage venting is available on 40D extruders for removal of tenacious volatiles, running ABS and similar materials.

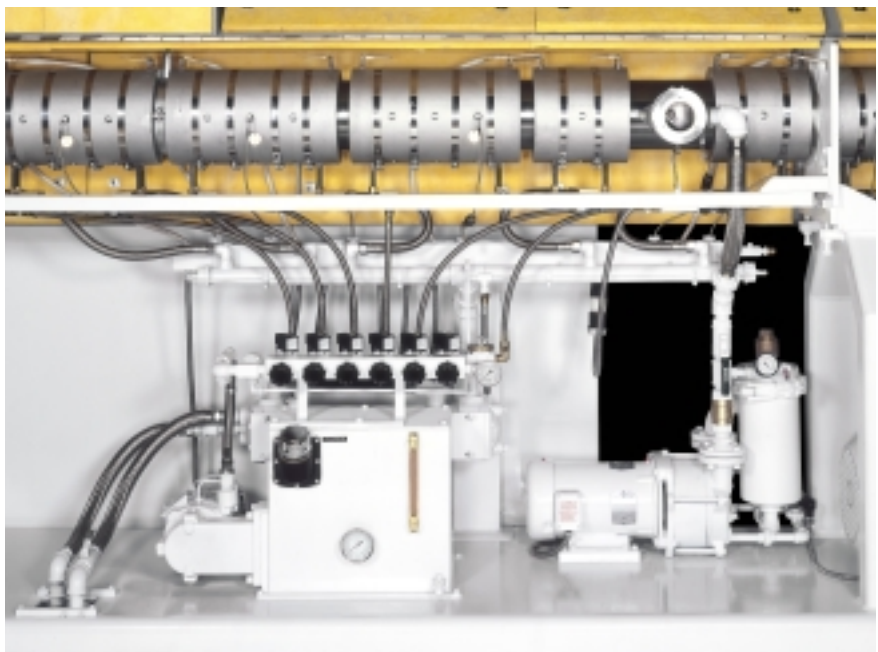



## Welex gear pumps:

Nothing enhances the performance of an extruder like a Welex gear pump. A gear pump provides absolute volumetric output stability to the extrusion system.

The gear pump is installed between the extruder and the die, and is run by a high-precision variable speed drive. The extruder motor speed is automatically regulated to maintain a constant feed pressure into the gear pump. This allows the extruder to function as a highly efficient plasticating device—not as an inefficient pump.

With a Welex gear pump, you'll have faster start-ups, with less scrap, eliminate surging, and the output of the extrusion system will be absolutely uniform.

Control systems are available in three models:

- Conventional discrete controller with drive controls in extruder panel
- Freestanding control panel with discrete controller and all drive and temperature controls for retrofit systems
- Ultima control, as part of a total Welex process control system

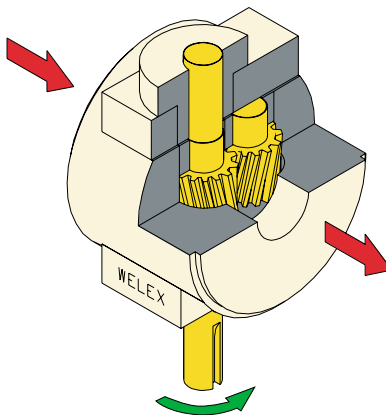

**Static mixers** assure perfect melt viscosity stability and color dispersion. When installed just prior to the die (or coextrusion feed block), they eliminate variations resulting from unstable viscosity caused by elastic memory in the polymer.

The mixer is installed in a heated streamlined housing and is practically self cleaning by flushing with successive products. Several types available depending on requirement.



**The combination** of a gear pump to assure output uniformity, followed by a static mixer to assure viscosity uniformity has opened a new era in extrusion. You must try these devices to believe the results. Once you do, you won't know how you managed without them all these years. Be careful! Your operators won't run your old machines. Your customers will demand the product quality of your new Welex gear pump/static mixer equipped line.

Pump Model	Displacement cc/rev	Motor hp	Maximum rpm	lb/h/rpm sp. gr. 1.0	kg/h/rpm sp. gr. 1.0	Maximum lb/h	Maximum kg/h	Extruder Size
28	10.2	3	200	1.32	0.61	265	120	1¼" - 2"
36	25.6	5	175	3.36	1.53	590	270	2" - 2½"
45	46.3	10	175	6.06	2.78	1060	480	2½" - 3½"
56	92.6	20	175	12.18	5.55	2130	970	3½" - 4½"
70	176	40	140	23.22	10.56	3250	1480	4½" - 6"
90	371	50	120	48.96	22.26	5840	2660	6" - 8"
110	716	75	120	94.51	42.96	11340	5160	8" - 10"

## Process Control:

---

**Welex control panels** provide precise, reliable control—essential for efficient extruder performance. Our electrical panels are designed with careful consideration given to ease of use, operator safety, and low maintenance.

Our standard panels include:

- Digital temperature controllers
- Long life mercury pool hermetically sealed contactors (solid state contactors optional)
- Circuit breakers for quick resets
- An ammeter to monitor each circuit
- Motor speed and load indicators
- Ten turn precision motor speed control
- Melt temperature indicator

To maintain components at proper temperature, panels are equipped with filtered air circulating fans (for high ambient temperature locations, air conditioners can be provided). Wiring is to highest electrical standards and can be supplied to meet local codes if we are advised about special requirements. Each panel is protected by a door interlocked main disconnect switch and a key locked door handle.

Welex control cabinets are usually premounted directly on the extruder base and prewired to the extruder. The extruder and accessory drives are incorporated into this panel for ease of installation.

Welex Ultima supervisory microprocessor control systems optionally available.

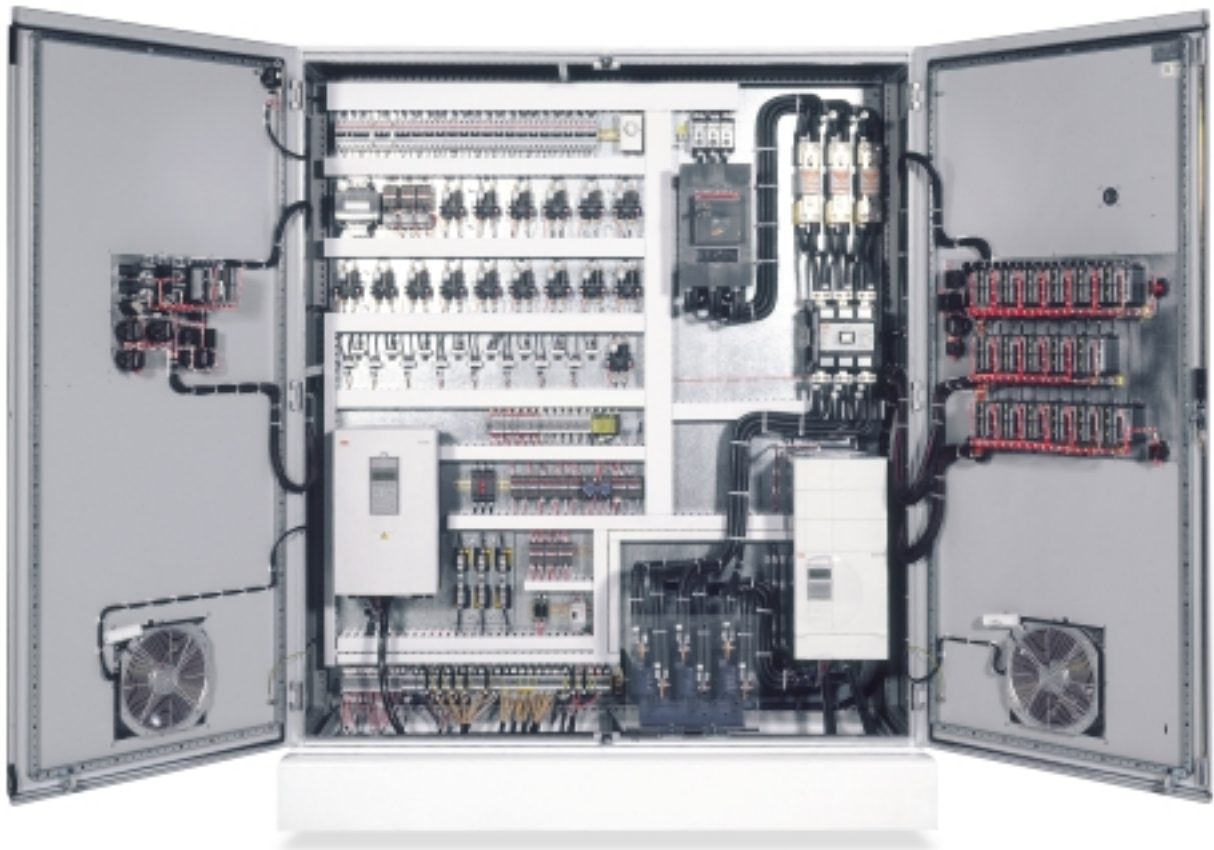

## We were first in coextrusion. And we still are.

Welex pioneered sheet coextrusion in 1967. Since then, we have been in the forefront of all multilayer sheet extrusion.

Coextrusion is the simplest method of producing multilayer sheet. Structured sheets have continuously opened up large new markets for plastics in the packaging, automotive and appliance markets (among others).

- Barrier sheet
- Multicolor sheet
- High gloss polystyrene sheet
- Refrigerator sheet
- Scrap encapsulation

Welex is the only extruder builder who can supply a complete coextrusion system based solely on our own technology. We use our own patented and well proven modular feed block system.

The layers are combined in a feed block and flow through a normal single channel die to produce any desired

structure. We have built lines with up to 8 extruders, each running a different material. One extruder can produce several layers in a structure.

### Welex feed block advantages:

- Easiest to adjust
- Interchangeable cassette inserts
- Modular add-on design for expanded needs
- Lowest cost
- Simplest flow arrangement
- Single source responsibility

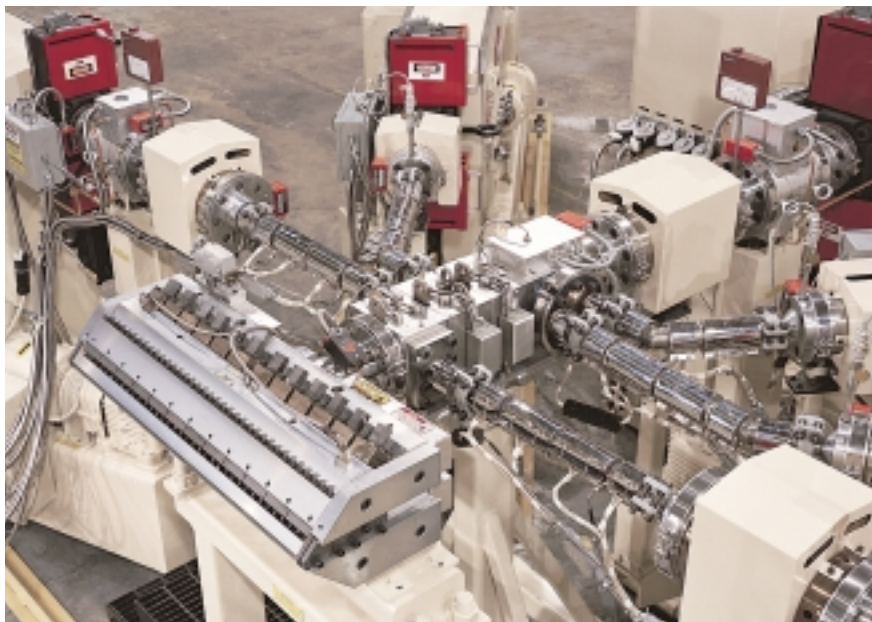

### Some common structures produced on Welex coextrusion lines:

#### High gloss sheet for dairy containers

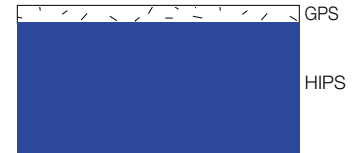

#### Multicolor sheet for color cups

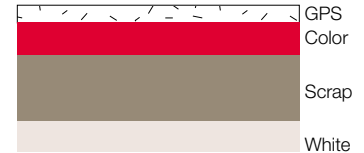

#### Long shelf life retortable and aseptic filled containers

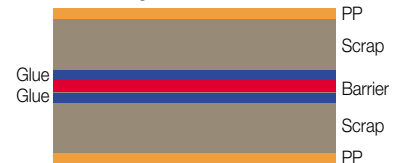

#### Dual barrier sheet for high barrier containers

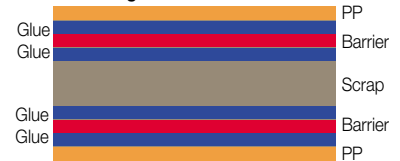

#### Form/fill/seal high barrier containers

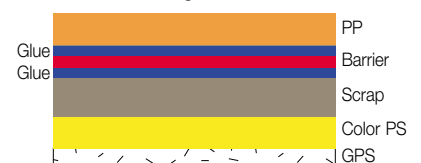

#### HCFC resistant refrigerator sheet

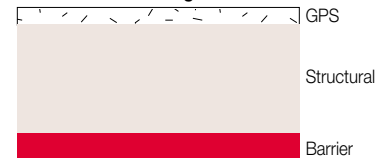

#### Polyside™ food service folding boxes



#### Polyside™ barrier sheet with single polymer edges



Polyside is a trademark of Welex, Inc.

## 2½" (65mm) Mark III Heavy Duty

<b>Nominal Screw Diameter</b>	2½" (65mm)		
<b>Effective Length/Diameter Ratio</b>	24D 30D 36D 40D		
<b>Operating Pressure</b>	10,000 psi maximum (700 bar)		
<b>Feed Opening Size</b>	3½" X 4½" rectangular centered. Special round opening available for use with crammer feeder or melt feed.		
<b>Die Adapter Gate</b>	4 bolt swing gate with heater standard. Flange, C clamp and others available.		
<b>Transmission Type</b>	Heavy duty reducer with heat treated double reduction helical gears.		
<b>Stock Gear Ratios and Capacities (1750 rpm input speed)</b>	Ratio	Screw rpm	hp
	7.9:1	222	253
	8.8:1	199	220
	11.3:1	155	186
	14.55:1	120	160
	18.12:1	97	132
	22.0:1	80	100
	(24 hour continuous rating AGMA Class II)		
	Other ratios available between extremes listed above.		
<b>Drive Motor Size</b>	40-125 hp		
<b>Thrust Bearing Rating</b>	1,900,000 hours B-10 at 5000 psi, 100 rpm.		
<b>Type of Heater</b>	Cast in aluminum resistance heaters with liquid cooling coils.		
<b>Number of Zones</b>	4-6 on cylinder, 1 on gate.		
<b>Heater Wattage</b>	30 kW approximately (30D).		
<b>Cooling System</b>	Automatic closed circuit liquid cooling with precision rate control. 150,000 Btu/h capacity.		
<b>Control Cabinet</b>	Premounted, fully wired, dust tight with interlocked doors and aluminum engraved instrument panel. Free standing panel optional.		
<b>Approximate Weight</b>	6,500 lbs. (3,000 kg)		
<b>Output Capacity</b>	Material	lb/h	kg/h
	HIPS/PET	250-500	110-225
	LDPE	250-400	110-180
	FPVC	250-400	110-180
	HDPE/PP	250-400	110-180
	ABS	250-400	110-180

Output rates are typical for this machine. Because of variations in materials and operating conditions, these figures do not imply any guarantee. Specifications subject to change without notice.

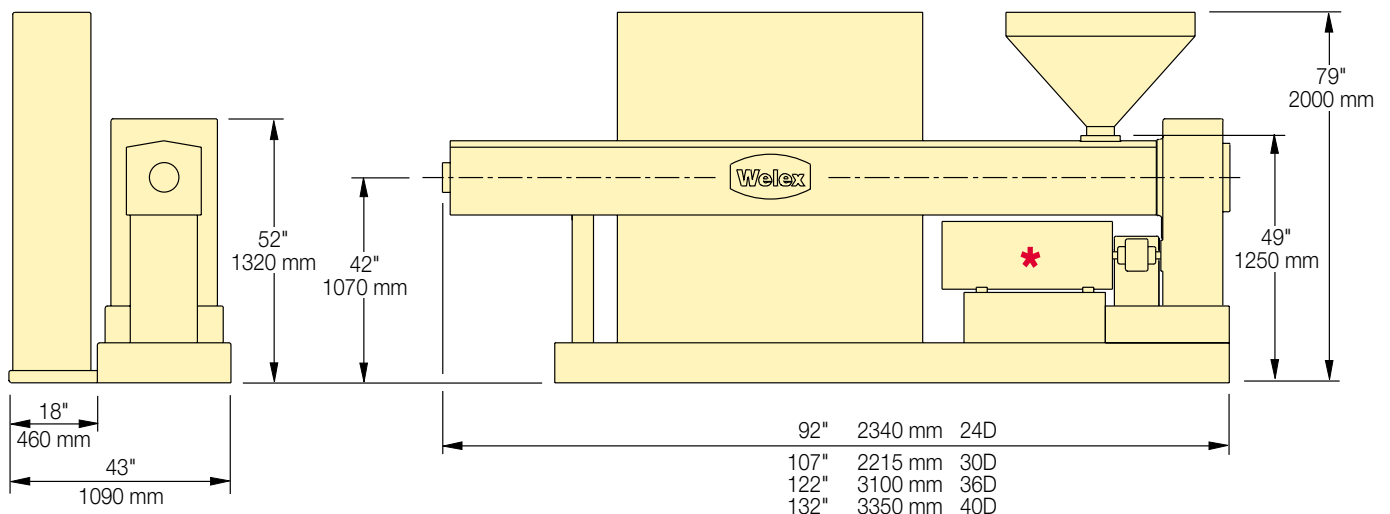

\* "Z" In-line configuration also available

# 3½" (90mm) Mark III Heavy Duty

<b>Nominal Screw Diameter</b>	3½" (90mm)		
<b>Effective Length/Diameter Ratio</b>	24D 30D 36D 40D		
<b>Operating Pressure</b>	10,000 psi maximum (700 bar)		
<b>Feed Opening Size</b>	5" X 5½" rectangular centered. Special round opening available for use with crammer feeder or melt feed.		
<b>Die Adapter Gate</b>	4 bolt swing gate with heater standard. Flange, C clamp and others available.		
<b>Transmission Type</b>	Heavy duty reducer with heat treated double reduction helical gears.		
<b>Stock Gear Ratios and Capacities</b> (1750 rpm input speed)	Ratio	Screw rpm	hp
	7.35:1	238	580
	9.93:1	176	480
	11.37:1	154	458
	13.89:1	126	350
	17.65:1	99	280
	20.13:1	87	240
	(24 hour continuous rating AGMA Class II)		
	Other ratios available between extremes listed above.		
<b>Drive Motor Size</b>	100-250 hp		
<b>Thrust Bearing Rating</b>	300,000 hours B-10 at 5000 psi, 100 rpm.		
<b>Type of Heater</b>	Cast in aluminum resistance heaters with liquid cooling coils.		
<b>Number of Zones</b>	4-6 on cylinder, 1 on gate.		
<b>Heater Wattage</b>	40 kW approximately (30D).		
<b>Cooling System</b>	Automatic closed circuit liquid cooling with precision rate control. 150,000 Btu/h capacity.		
<b>Control Cabinet</b>	Premounted, fully prewired, dust tight with interlocked doors and aluminum engraved instrument panel. Free standing panel optional.		
<b>Approximate Weight</b>	11,000 lbs. (5,000 kg)		
<b>Output Capacity</b>	Material	lb/h	kg/h
	HIPS/PET	800-1,000	360-450
	LDPE	600-1,000	270-450
	FPVC	600-1,000	270-450
	HDPE/PP	600-800	270-360
	ABS	600-800	270-360
	Output rates are typical for this machine. Because of variations in materials and operating conditions, these figures do not imply any guarantee. Specifications subject to change without notice.		

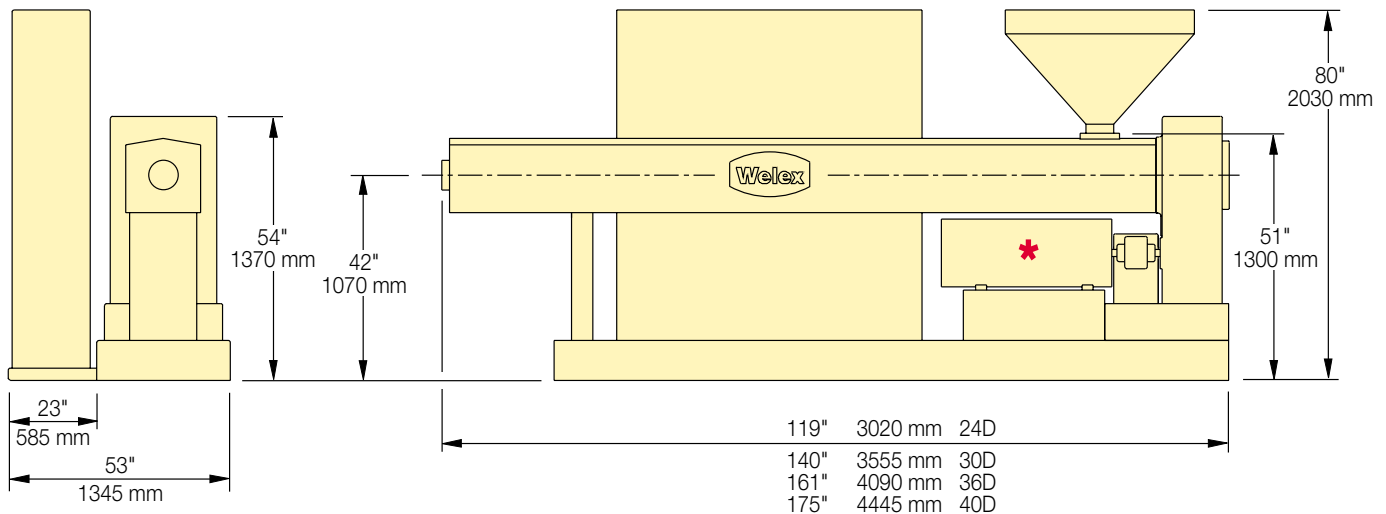

\* "Z" In-line configuration also available

# 4½" (120mm) Mark III Heavy Duty

<b>Nominal Screw Diameter</b>	4½" (120mm)		
<b>Effective Length/Diameter Ratio</b>	24D 30D 36D 40D		
<b>Operating Pressure</b>	10,000 psi maximum (700 bar)		
<b>Feed Opening Size</b>	6" X 7" rectangular centered. Special round opening available for use with crammer feeder or melt feed.		
<b>Die Adapter Gate</b>	4 bolt swing gate with heater standard. Flange, C clamp and others available.		
<b>Transmission Type</b>	Heavy duty reducer with heat treated double reduction helical gears.		
<b>Stock Gear Ratios and Capacities (1750 rpm input speed)</b>	Ratio	Screw rpm	hp
	7.62:1	230	1000
	10.00:1	175	760
	11.87:1	147	700
	13.93:1	126	600
	17.72:1	99	480
	19.84:1	88	412
	(24 hour continuous rating AGMA Class II)		
	Other ratios available between extremes listed above.		
<b>Drive Motor Size</b>	200-400 hp		
<b>Thrust Bearing Rating</b>	300,000 hours B-10 at 5000 psi, 100 rpm.		
<b>Type of Heater</b>	Cast in aluminum resistance heaters with liquid cooling coils.		
<b>Number of Zones</b>	4-6 on cylinder, 1 on gate.		
<b>Heater Wattage</b>	60 kW approximately (30D).		
<b>Cooling System</b>	Automatic closed circuit liquid cooling with precision rate control. 150,000 Btu/h capacity.		
<b>Control Cabinet</b>	Premounted, fully wired, dust tight with interlocked doors and aluminum engraved instrument panel. Free standing panel optional.		
<b>Approximate Weight</b>	18,000 lbs. (8,000 kg)		
<b>Output Capacity</b>	Material	lb/h	kg/h
	HIPS/PET	1,200-2,000	550-900
	LDPE	800-1,500	360-700
	FPVC	800-1,500	360-700
	HDPE/PP	800-1,400	360-630
	ABS	800-1,400	360-630
	Output rates are typical for this machine. Because of variations in materials and operating conditions, these figures do not imply any guarantee. Specifications subject to change without notice.		

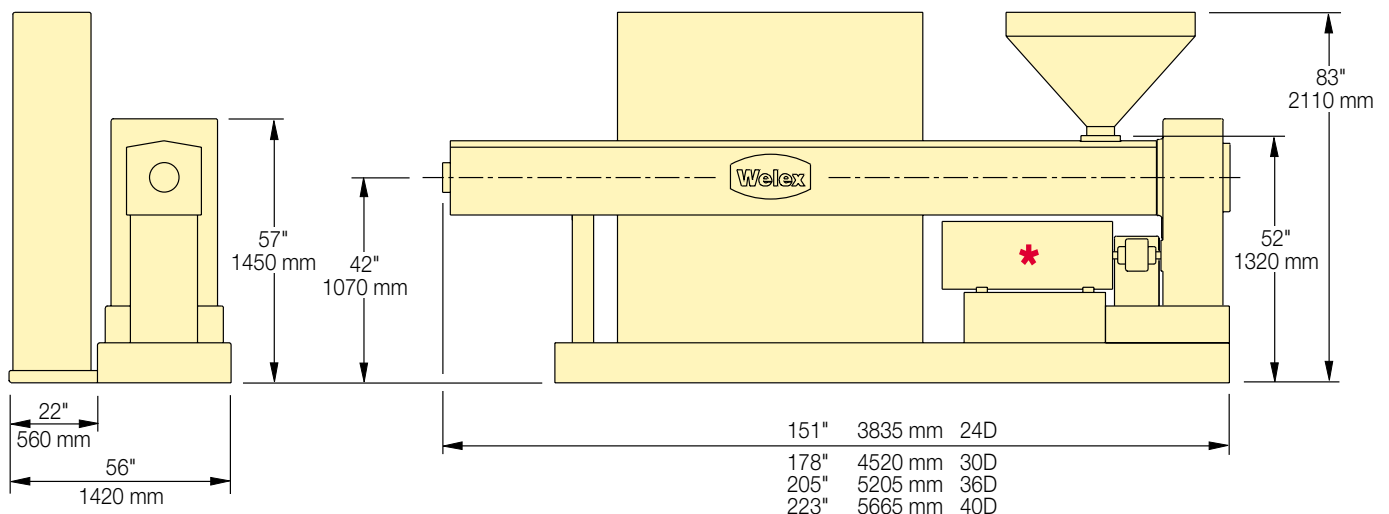

\* "Z" In-line configuration also available

# 5" (130mm) Mark III Heavy Duty

<b>Nominal Screw Diameter</b>	5" (130mm)																					
<b>Effective Length/Diameter Ratio</b>	24D 30D 36D 40D																					
<b>Operating Pressure</b>	10,000 psi maximum (700 bar)																					
<b>Feed Opening Size</b>	6" X 7" rectangular centered. Special round opening available for use with crammer feeder or melt feed.																					
<b>Die Adapter Gate</b>	4 bolt swing gate with heater standard. Flange, C clamp and others available.																					
<b>Transmission Type</b>	Heavy duty reducer with heat treated double reduction helical gears.																					
<b>Stock Gear Ratios and Capacities (1750 rpm input speed)</b>	<table border="1"> <thead> <tr> <th>Ratio</th> <th>Screw rpm</th> <th>hp</th> </tr> </thead> <tbody> <tr> <td>7.62:1</td> <td>230</td> <td>1000</td> </tr> <tr> <td>10.00:1</td> <td>175</td> <td>760</td> </tr> <tr> <td>11.87:1</td> <td>147</td> <td>700</td> </tr> <tr> <td>13.93:1</td> <td>126</td> <td>600</td> </tr> <tr> <td>17.72:1</td> <td>99</td> <td>480</td> </tr> <tr> <td>19.84:1</td> <td>88</td> <td>412</td> </tr> </tbody> </table>	Ratio	Screw rpm	hp	7.62:1	230	1000	10.00:1	175	760	11.87:1	147	700	13.93:1	126	600	17.72:1	99	480	19.84:1	88	412
Ratio	Screw rpm	hp																				
7.62:1	230	1000																				
10.00:1	175	760																				
11.87:1	147	700																				
13.93:1	126	600																				
17.72:1	99	480																				
19.84:1	88	412																				

(24 hour continuous rating AGMA Class II)  
Other ratios available between extremes listed above.

<b>Drive Motor Size</b>	300-500 hp																		
<b>Thrust Bearing Rating</b>	250,000 hours B-10 at 5000 psi, 100 rpm.																		
<b>Type of Heater</b>	Cast in aluminum resistance heaters with liquid cooling coils.																		
<b>Number of Zones</b>	5-7 on cylinder, 1 on gate.																		
<b>Heater Wattage</b>	70 kW approximately (30D).																		
<b>Cooling System</b>	Automatic closed circuit liquid cooling with precision rate control. 150,000 Btu/h capacity.																		
<b>Control Cabinet</b>	Premounted, fully prewired, dust tight with interlocked doors and aluminum engraved instrument panel. Free standing panel optional.																		
<b>Approximate Weight</b>	22,000 lbs. (10,000 kg)																		
<b>Output Capacity</b>	<table border="1"> <thead> <tr> <th>Material</th> <th>lb/h</th> <th>kg/h</th> </tr> </thead> <tbody> <tr> <td>HIPS/PET</td> <td>1,400-2,500</td> <td>650-1,150</td> </tr> <tr> <td>LDPE</td> <td>1,000-1,900</td> <td>500-850</td> </tr> <tr> <td>FPVC</td> <td>1,000-1,900</td> <td>500-850</td> </tr> <tr> <td>HDPE/PP</td> <td>1,000-1,800</td> <td>500-850</td> </tr> <tr> <td>ABS</td> <td>1,000-1,800</td> <td>500-850</td> </tr> </tbody> </table>	Material	lb/h	kg/h	HIPS/PET	1,400-2,500	650-1,150	LDPE	1,000-1,900	500-850	FPVC	1,000-1,900	500-850	HDPE/PP	1,000-1,800	500-850	ABS	1,000-1,800	500-850
Material	lb/h	kg/h																	
HIPS/PET	1,400-2,500	650-1,150																	
LDPE	1,000-1,900	500-850																	
FPVC	1,000-1,900	500-850																	
HDPE/PP	1,000-1,800	500-850																	
ABS	1,000-1,800	500-850																	

Output rates are typical for this machine. Because of variations in materials and operating conditions, these figures do not imply any guarantee. Specifications subject to change without notice.

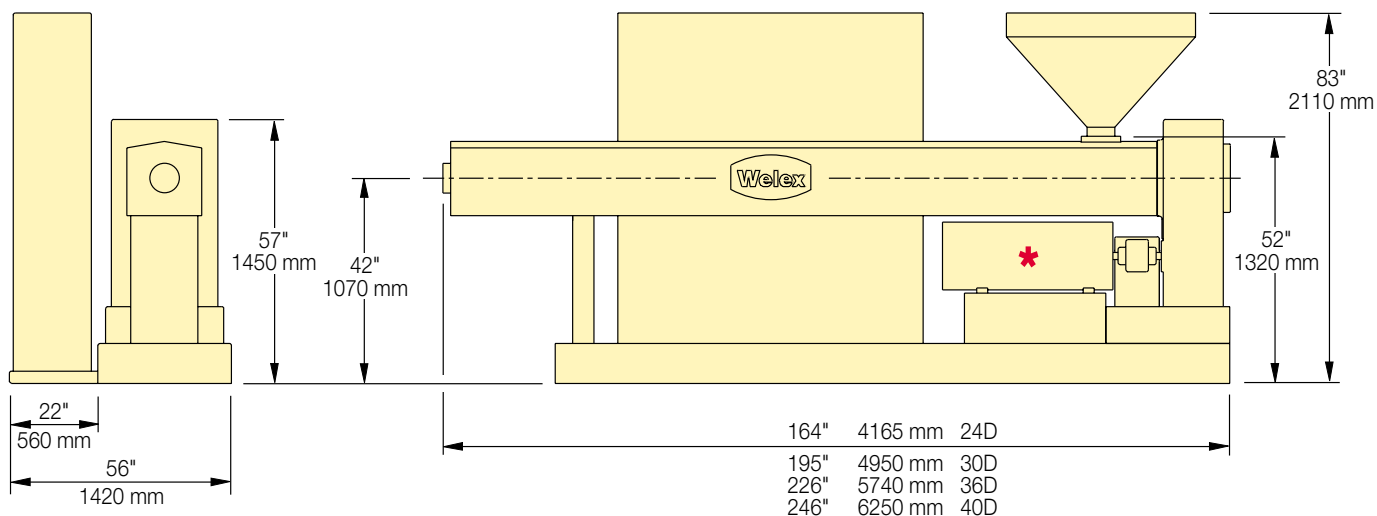

\* "Z" In-line configuration also available

# 6" (150mm) Mark III Heavy Duty

<b>Nominal Screw Diameter</b>	6" (150mm)		
<b>Effective Length/Diameter Ratio</b>	24D 30D 36D 40D		
<b>Operating Pressure</b>	10,000 psi maximum (700 bar)		
<b>Feed Opening Size</b>	8" X 10" rectangular centered. Special round opening available for use with crammer feeder or melt feed.		
<b>Die Adapter Gate</b>	6 bolt swing gate with heater standard. Flange, C clamp and others available.		
<b>Transmission Type</b>	Heavy duty reducer with heat treated double reduction helical gears.		
<b>Stock Gear Ratios and Capacities (1750 rpm input speed)</b>	Ratio	Screw rpm	hp
	7.5:1	232	1500
	10.03:1	174	1250
	11.29:1	155	1200
	13.43:1	129	1000
	17.64:1	100	800
	25.48:1	69	550
	(24 hour continuous rating AGMA Class II)		
	Other ratios available between extremes listed above.		
<b>Drive Motor Size</b>	300-700 hp		
<b>Thrust Bearing Rating</b>	110,000 hours B-10 at 5000 psi, 100 rpm.		
<b>Type of Heater</b>	Cast in aluminum resistance heaters with liquid cooling coils.		
<b>Number of Zones</b>	5-7 on cylinder, 1 on gate.		
<b>Heater Wattage</b>	90 kW approximately (30D).		
<b>Cooling System</b>	Automatic closed circuit liquid cooling with precision rate control. 200,000 Btu/h capacity.		
<b>Control Cabinet</b>	Premounted, fully prewired, dust tight with interlocked doors and aluminum engraved instrument panel. Free standing panel optional.		
<b>Approximate Weight</b>	30,000 lbs. (13,500 kg)		
<b>Output Capacity</b>	Material	lb/h	kg/h
	HIPS/PET	2,500-4,000	1,150-1,800
	LDPE	1,500-2,500	700-1,150
	FPVC	1,500-2,500	700-1,150
	HDPE/PP	1,500-2,500	700-1,150
	ABS	1,500-2,500	700-1,150
	Output rates are typical for this machine. Because of variations in materials and operating conditions, these figures do not imply any guarantee. Specifications subject to change without notice.		

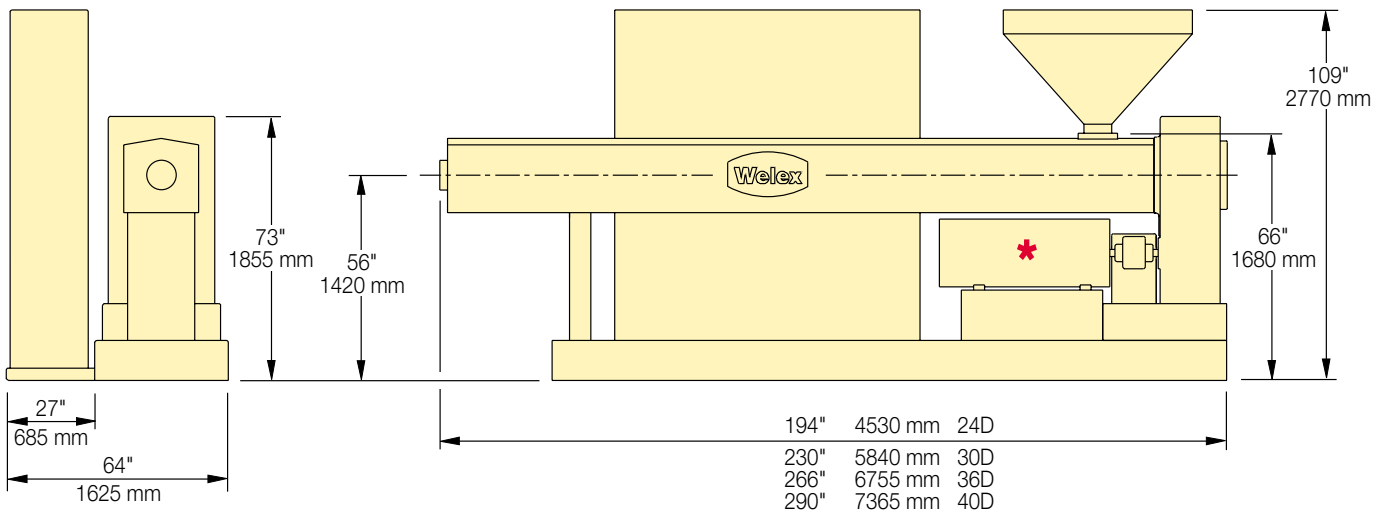

\* "Z" In-line configuration also available

# 7" (175mm) Mark III Heavy Duty

<b>Nominal Screw Diameter</b>	7" (175mm)	
<b>Effective Length/Diameter Ratio</b>	24D 30D 36D 40D	
<b>Operating Pressure</b>	10,000 psi maximum (700 bar)	
<b>Feed Opening Size</b>	8" X 10" rectangular centered. Special round opening available for use with crammer feeder or melt feed.	
<b>Die Adapter Gate</b>	6 bolt swing gate with heater standard. Flange, C clamp and others available.	
<b>Transmission Type</b>	Heavy duty reducer with heat treated double reduction helical gears.	
<b>Stock Gear Ratios and Capacities</b>	Ratio	Screw rpm
<b>(1750 rpm input speed)</b>	8.61:1	203
	11.75:1	150
	13.20:1	133
	15.38:1	114
	17.50:1	100
		hp
		1500
		1450
		1300
		1150
		970
	(24 hour continuous rating AGMA Class II)	
	Other ratios available between extremes listed above.	
<b>Drive Motor Size</b>	500-700 hp	
<b>Thrust Bearing Rating</b>	90,000 hours B-10 at 5000 psi, 100 rpm.	
<b>Type of Heater</b>	Cast in aluminum resistance heaters with liquid cooling coils.	
<b>Number of Zones</b>	6-8 on cylinder, 1 on gate.	
<b>Heater Wattage</b>	115 kW approximately (30D).	
<b>Cooling System</b>	Automatic closed circuit liquid cooling with precision rate control. 200,000 Btu/h capacity.	
<b>Control Cabinet</b>	Premounted, fully prewired, dust tight with interlocked doors and aluminum engraved instrument panel. Free standing panel optional.	
<b>Approximate Weight</b>	35,000 lbs. (16,000 kg)	
<b>Output Capacity</b>	Material	lb/h
	HIPS/PET	3,300-5,000
	LDPE	2,200-3,300
	FPVC	2,200-3,300
	HDPE/PP	2,200-3,300
	ABS	2,200-3,300
		kg/h
		1,500-2,300
		1,000-1,500
		1,000-1,500
		1,000-1,500
		1,000-1,500

Output rates are typical for this machine. Because of variations in materials and operating conditions, these figures do not imply any guarantee. Specifications subject to change without notice.

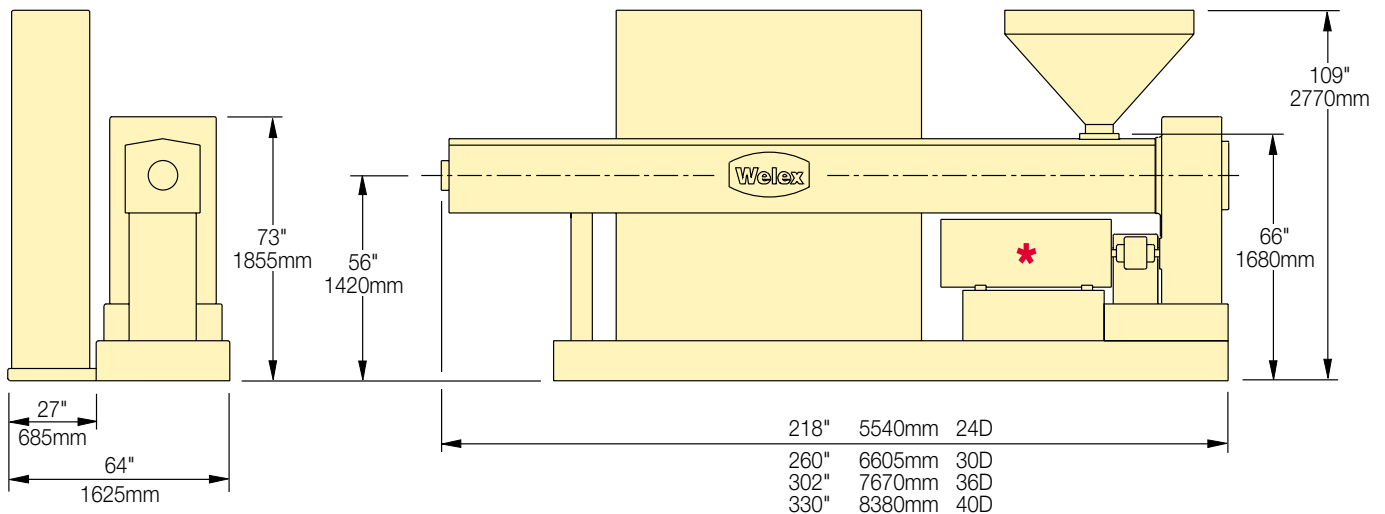

\* "Z" In-line configuration also available

# 8" (200mm) Mark III Heavy Duty

<b>Nominal Screw Diameter</b>	8" (200mm)		
<b>Effective Length/Diameter Ratio</b>	24D 30D 36D 40D		
<b>Operating Pressure</b>	7,500 psi maximum (500 bar)		
<b>Feed Opening Size</b>	12" X 14" rectangular centered. Special round opening available for use with crammer feeder or melt feed.		
<b>Die Adapter Gate</b>	6 bolt swing gate with heater standard. Flange, C clamp and others available.		
<b>Transmission Type</b>	Heavy duty reducer with heat treated double reduction helical gears.		
<b>Stock Gear Ratios and Capacities (1750 rpm input speed)</b>	Ratio	Screw rpm	hp
	10.0:1	175	1500
	11.7:1	150	1450
	14.0:1	125	1290
	16.85:1	104	1180
	22.77:1	77	850
	(24 hour continuous rating AGMA Class II)		
	Other ratios available between extremes listed above.		
<b>Drive Motor Size</b>	500-1,500 hp		
<b>Thrust Bearing Rating</b>	83,000 hours B-10 at 5000 psi, 100 rpm.		
<b>Type of Heater</b>	Cast in aluminum resistance heaters with liquid cooling coils.		
<b>Number of Zones</b>	6-9 on cylinder, 1 on gate.		
<b>Heater Wattage</b>	150 kW approximately (30D).		
<b>Cooling System</b>	Automatic closed circuit liquid cooling with precision rate control. 300,000 Btu/h capacity.		
<b>Control Cabinet</b>	Free standing, dust tight, with interlocked doors and aluminum engraved instrument panel.		
<b>Approximate Weight</b>	40,000 lbs. (18,000 kg)		
<b>Output Capacity</b>	Material	lb/h	kg/h
	HIPS/PET	4,000-7,000	1,800-3,200
	LDPE	3,000-5,000	1,400-2,300
	FPVC	3,000-5,000	1,400-2,300
	HDPE/PP	3,000-4,000	1,400-1,800
	ABS	3,000-4,000	1,400-1,800

Output rates are typical for this machine. Because of variations in materials and operating conditions, these figures do not imply any guarantee. Specifications subject to change without notice.

## 10" (250mm) and larger extruders available.

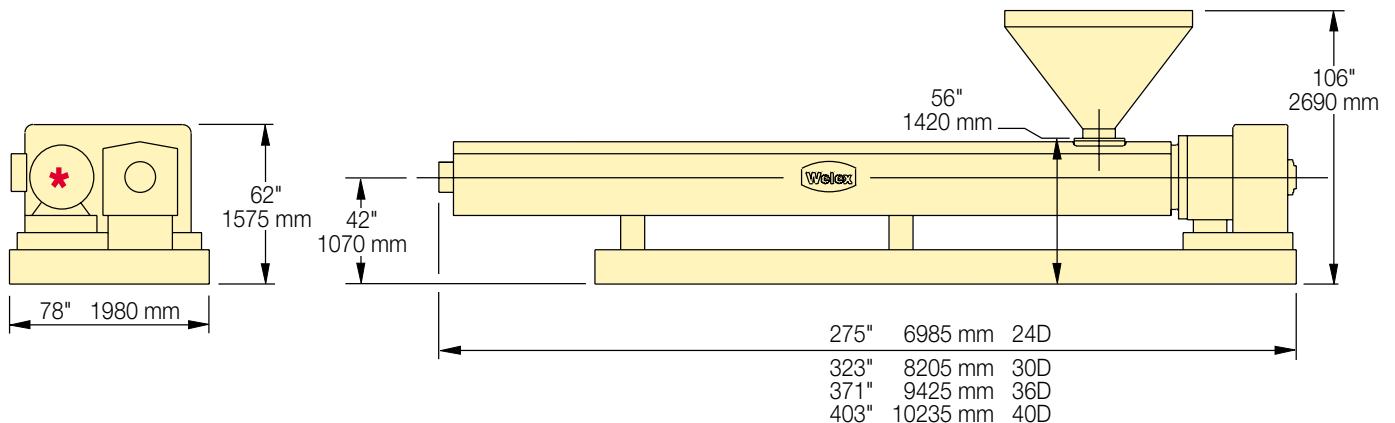

\* "Z" In-line configuration also available

## What makes Welex different?

---

Welex was founded in 1967 by a group of successful, experienced extrusion engineers. Since then, our list of patents, innovations, and pioneering firsts has earned Welex an ever-growing following of satisfied and loyal customers, worldwide.

We've remained under the same family management (now including the second generation) since the beginning—a continuity unmatched by any other extruder builder.

No problem with parts, service, or system engineering.

Welex extruders are backed by a worldwide sales and service organization that you can call on for help at any time. We employ the most qualified field service staff and maintain the most complete spare parts inventory in the industry, so that we can supply whatever is needed for any Welex extruder ever made.

Whether you're near us or half a world away, we understand your needs, and we'd like to work with you to meet them. In your language and measurement system. Our equipment meets the CEANSI and NFPA standards —plus other certifications on request.

Call your local Welex representative (listed on our home page on the Internet), or contact us directly.



Welex Incorporated  
1600 Union Meeting Road, Blue Bell, PA 19422 U.S.A.  
www.welex.com • E-mail: welex@welex.com  
Tel: 215-542-8000 • Fax: 215-542-9841